

METHOD OF INCLINED VELOCITIES IN THE AIR ION MOBILITY ANALYSIS

H. TAMMET

Institute of Environmental Physics, University of Tartu, Tartu, Estonia

Hannes.Tammet@ut.ee

ABSTRACT: *Loscertales* [1998] proposed an inclined electric field in a mobility analyzer with the aim to suppress the Brownian broadening of the transfer function and improve the mobility resolution. The inclined field can be accomplished by using inclined grids as proposed by *Tammet* [1999]. The ways of realization of the method of inclined grids are described in the present paper. A low concentration of the ions necessitates intentional instrumental broadening of the

transfer function in the atmospheric measurements. Thus the Brownian diffusion is not the main factor of mobility resolution in atmospheric research. However, the method of inclined grids has some unexpected at first advantages that make it to a promising method. A considerable advantage is the reduced effect of random errors that are caused by the alpha decay of radon daughters deposited in the analyzer.

INTRODUCTION

The measurement of air ion mobility distribution is a key for understanding the role of ion-induced nucleation in the atmosphere. Traditional measurement methods are the drift tube or the time-of-flight method, and the aspiration method or the method of transversal velocities. An alternative method of parallel velocities proposed by *Zeleny* [1898] is forgotten today. Drift tubes are popular in high-resolution laboratory measurements. They make available the Brownian limit of mobility resolution $\delta = \delta_o = \sqrt{2kT/(qV)}$. The resolution of an aspiration condenser is worse, $\delta = \kappa\delta_o$, $\kappa > 1$, and the resolution of the *Zeleny* instrument is better, $\kappa < 1$. Aspiration condenser is still preferred in the atmospheric measurements in spite of the fact that its Brownian limit of resolution is low. *Loscertales* [1998] introduced the method of inclined velocities that composes high resolution ($\kappa < 1$) with the advantages of an aspiration condenser.

Unfortunately, the technical realization of the method of inclined velocities remained an unsolved problem. Non-equipotential electrodes

proposed by *Loscertales* encounter technological difficulties. An alternative way to accomplish the inclined field is the method of inclined grids proposed in a former paper by *Tammet* [1999]. The method was explained in this paper as an idea only, and the details that are essential in the technical realization were not discussed. A further analysis shows that the realization of the method of inclined grids directly according to the drawing in the paper [*Tammet*, 1999] is not reasonable. More developed ways to accomplish the method of inclined grids are explained in the current paper.

Three sections of the paper form three columns of the poster:

- overview of known methods,
- the plain IGMA,
- the modified IGMA.

The abbreviation IGMA means:

Inclined Grid Mobility Analyzer.

DRIFT TUBE

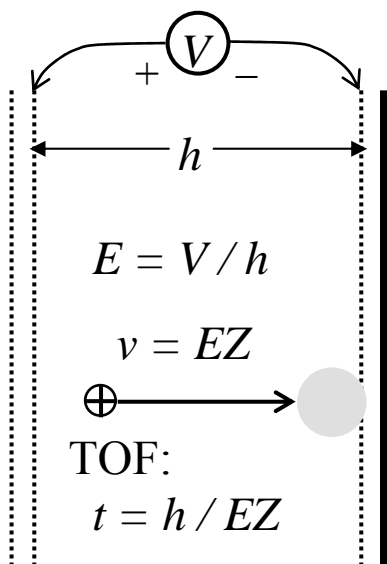

The time of flight (TOF) method and the drift tube are popular in laboratory research and in a method of chemical analysis called IMS (Ion Mobility Spectrometry), see *Eiceman and Karpas [1994]*. Drift tube was proposed simultaneously by *Van De Graaff 1928* and *Tyndall 1928*.

Mobility: $Z_o = \frac{h}{Et}$

Two possibilities: $\left. \begin{array}{l} h \text{ fixed } t \text{ measured} \\ t \text{ fixed } h \text{ measured} \end{array} \right\}$ resolution nearly the same

$$\delta = \frac{\sigma_Z}{Z_o} \approx \frac{\sigma_h}{h} \quad \& \quad \sigma_h = \sqrt{2Dt} = \sqrt{2 \frac{kTZ}{q} t} \quad \Rightarrow \quad \delta = \sqrt{2 \frac{kTZt}{qh^2}} = \sqrt{2 \frac{kT}{qV}}$$

Standard resolution δ_o : $\delta_o = \sqrt{2 \frac{kT}{qV}}$

q is the ion charge and V is the voltage between the beginning and the end of the drift path.

Example ($q = 1 \text{ e}$, $T = 20^\circ\text{C}$, any value of Z)

$V = 1 \text{ V}$	10 V	100 V	1000 V
$\delta_o = 22\%$	7%	2.2%	0.7%

The fact that the diffusion-limited resolution is determined by the energy ratio kT/qV has been shown by *Zeleny [1929]*. The direct molecular-kinetic interpretation of this result was explained by *Tammet [1970]* (see page 67 of the book).

PERPENDICULAR FLOW ANALYZER

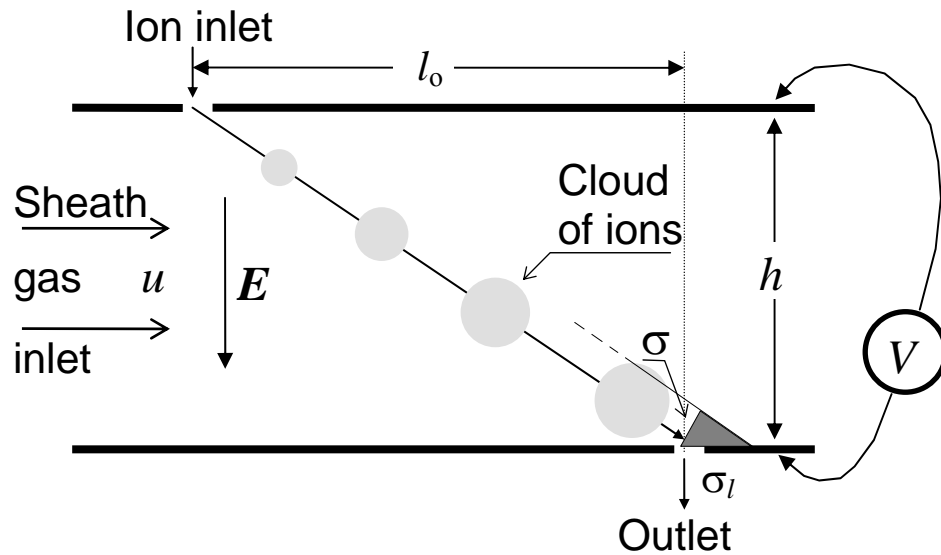

Plain condenser with a plug flow:

$$Z = \frac{uh^2}{Vl} = \frac{\text{const}}{l} \quad \& \quad \delta = \frac{\sigma_l}{l_0} \quad \& \quad \sigma_l = \sigma \sqrt{1 + \frac{h^2}{l_0^2}}$$

$$\Rightarrow \quad \delta = \delta_0 \sqrt{1 + \frac{h^2}{l_0^2}}$$

Solutions of specified problems have been given by many of authors, see *Flagan* [1998].

The resolution of a specific analyzer can be written as $\delta = f \times \delta_0$, where the factor f exceeds the value of 1 in any classic aspiration mobility analyzer. E.g., $f = \sqrt{1 + h^2 / l_0^2}$ in a plain aspiration condenser with a plug flow, where h is the distance between the electrodes and l_0 is the length of the condenser.

The problem of optimum length. $l_0 \rightarrow \infty \Rightarrow f \rightarrow 1$. Why not increase the length?

If $V = \text{const}$ & $l_0 \rightarrow \infty$ then $Re \rightarrow \infty$.

If $Re = \text{const}$, the optimum is at $l_0 = h$ and the best value of f is $f = \sqrt{2}$ [*Rosell-Llompart et al.* 1996].

PARALLEL FLOW ANALYZER

Actually, the limit of resolution δ_0 was over-passed already in the oldest mobility analyzer of Zeleny [1898]. The parallel flow method of Zeleny has been forgotten as it has an essential shortcoming: it does not allow injection and extraction of ions by means of air flows as is required in most applications. The air is blown

through two grids and the electric field forces the drift of ions against the air flow. The ions should be created inside the instrument between the grids. The ions of high mobility drift left in the Figure and those of low mobility drift right, being carried by air flow.

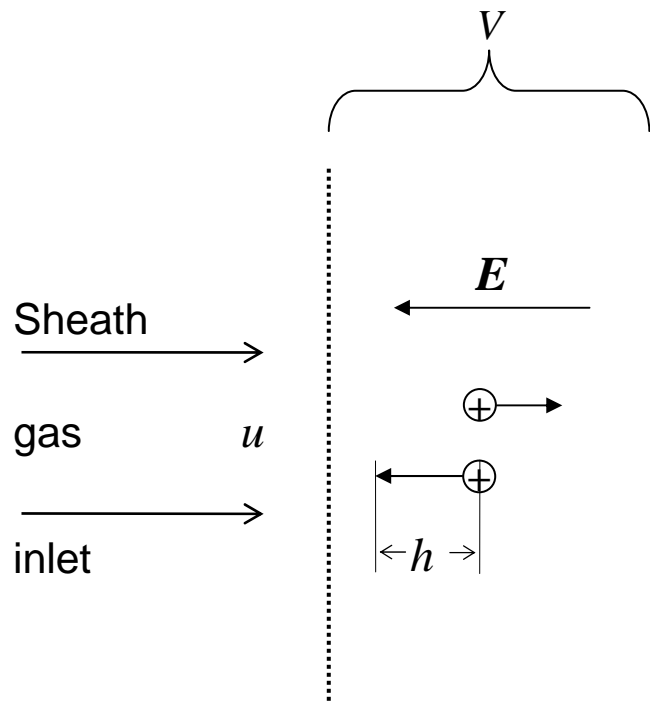

Calculation of the resolution:

Velocity $v = EZ - u$, drift along E during t: $h = EZt - ut$

$$Z = \frac{h}{Et} + \frac{u}{E} \quad \sigma_Z = \frac{\sigma_h}{Et} = \frac{1}{Et} \sqrt{2 \frac{kTZ}{q} t}$$

$$\delta = \sqrt{2 \frac{kT}{qE(EZt)}} = \sqrt{2 \frac{kT}{qE(h+ut)}}$$

$h + ut = h_{\text{Lagrange}}$, $E(h + ut) = W = \text{work of electrical force}$

$$\delta = \delta_0 \sqrt{\frac{h}{h_{\text{Lagrange}}}} = \sqrt{2 \frac{kT}{W}} < \delta_0 .$$

LOSCERTALES ANALYZER

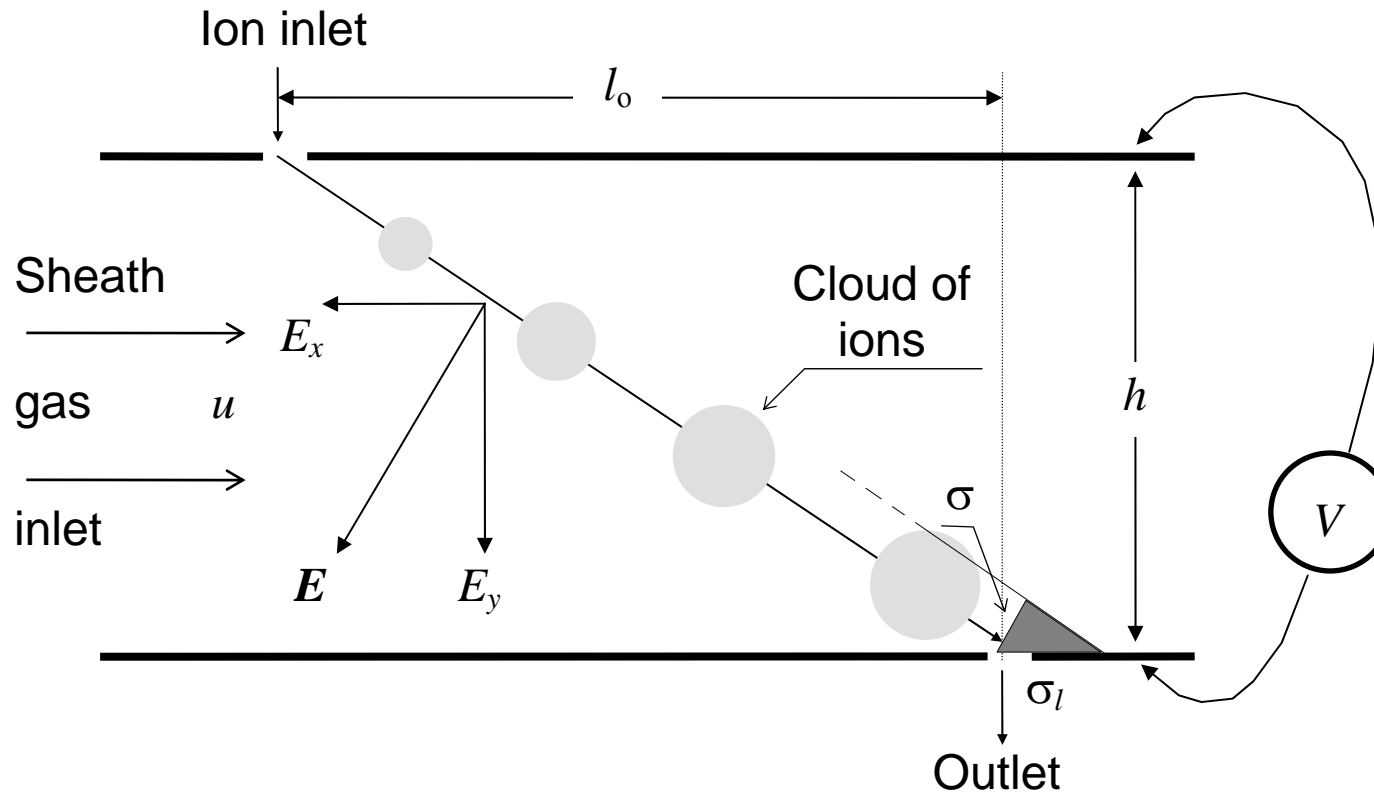

Loscertales [1998] proposed a new method improving the diffusion-limited mobility resolution by means of the longitudinal electric field in an aspiration mobility analyzer. The plain analyzer is explained in Figure. The plates of a Loscertales analyzer are not equipotential and the electric field is not perpendicular to the air flow as assumed in traditional mobility analyzers.

The deviation from a traditional parallel flow analyzer is characterized by the ratio of longitudinal and transverse components of the electric field, $Lo = E_x / E_y$. Calculations yield the result:

$$f = \sqrt{1 + \frac{l_0^2}{h^2}} / \left(Lo + \frac{l_0}{h} \right).$$

The value of Lo has no upper limit and the situation $f < 1$ is possible which seems to be paradoxical from the viewpoint of traditional interpretation explained above.

METHOD OF INCLINED GRIDS AS PROPOSED IN 1999

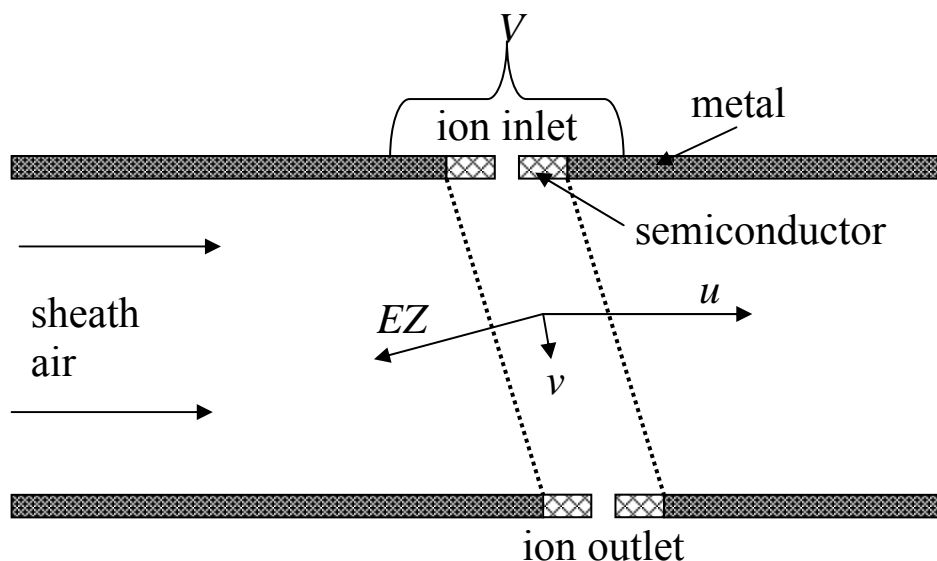

This is a modification of the Zeleny grid method. However, the configuration of fields is just the same as in a plain Loscertales analyzer.

The proposal of Loscertales to make an aspiration analyzer with non-equipotential electrodes has not materialized due to troublesome technical problems. A combination of the grid method of Zeleny and the non-equipotential electrode method of Loscertales promises easier technical realization of the instrument. The schematic design of the new instrument is explained left in Figure.

The orientation of the electric field in the analyzer is the same as in the Loscertales analyzer, and the diffusion-limited resolution is determined with the same equations.

As distinct from the Zeleny grid instrument, the new analyzer has inlet and outlet slits for ions like the traditional DMAs. The ions to be separated do not pass through the grids and there is no harmful effect of adsorption of ions on the grids. To the contrary, adsorption on the first grid is

even useful as a means of additionally cleaning the sheath air. An essential advantage of the method is that the grids suppress the turbulence and maintain the plug flow profile. The required total voltage in the inclined grid instrument is less than in the Loscertales instrument, and the voltage dividers are short and simple. Sheath air can be easily cleaned from background ions by the inclusion of additional grids into the air flow before the analyzer.

CLASSIFICATION OF THE METHODS

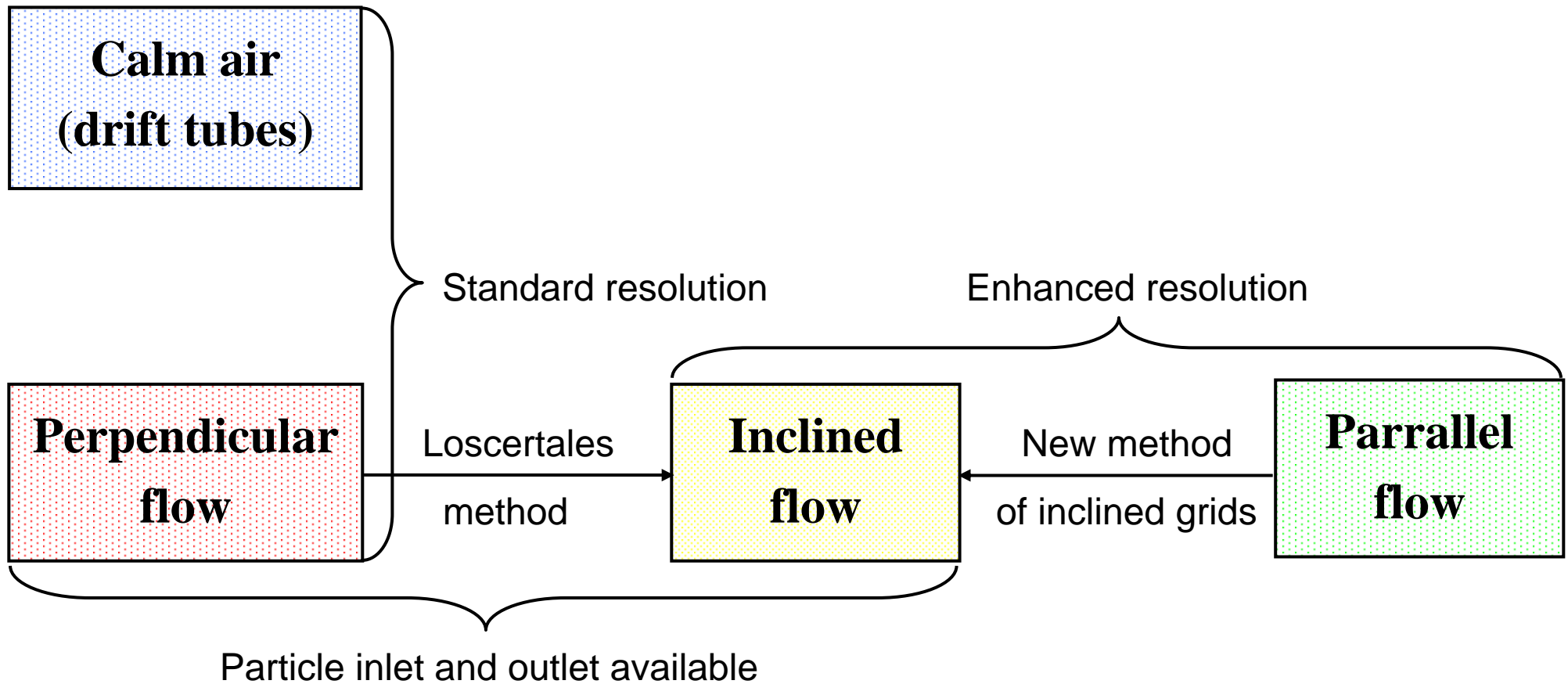

PLAIN IGMA

(Inclined Grid Mobility Analyzer)

The air inlet and outlet will distort the air flow and damage the performance of an IGMA when it is designed directly according to the proposal of 1999. An additional complication will be created by the requirement to keep the air inlet and outlet channels on definite potential levels and free of electric field. The theoretical model of this kind of instrument is complicated. The plain IGMA is a new instrument where plug air flow is easy to maintain in full profile and the correct theoretical calculation is simple.

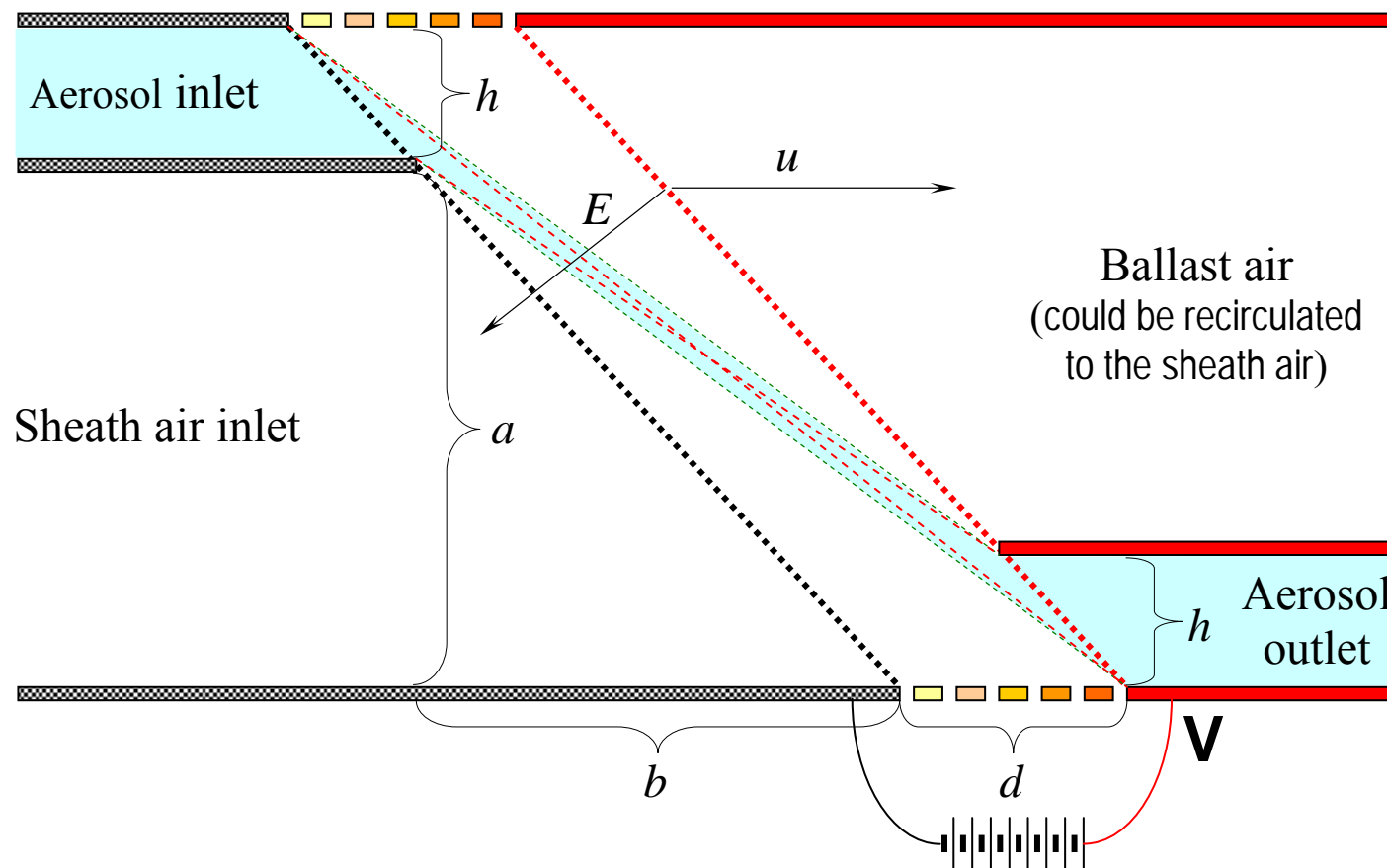

MONOMOBILE IONS PASSING A PLAIN IGMA

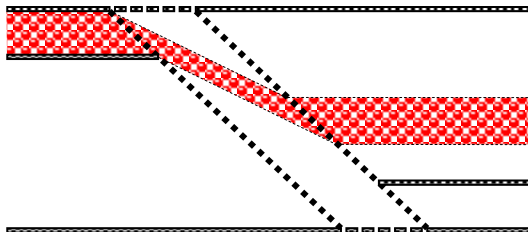

a) Voltage is too low or ions too slow.
No ions in outlet slit.

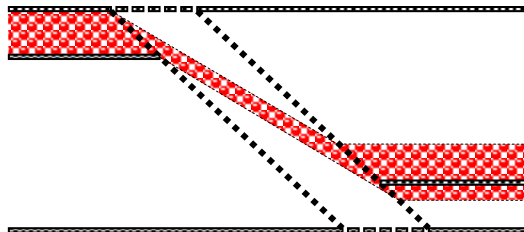

b) Voltage is low or ions are slow.
Part of ions in outlet slit.

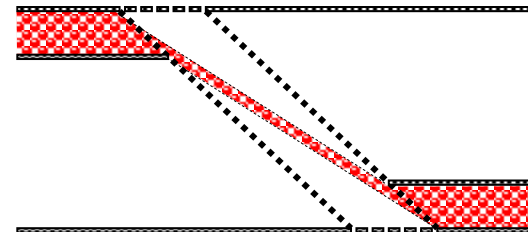

c) Ions are of central mobility.
All ions in outlet slit.

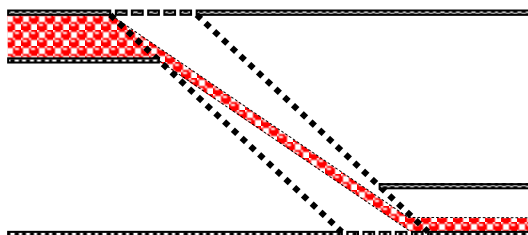

d) Voltage is high or ions are fast.
Part of ions in outlet slit.

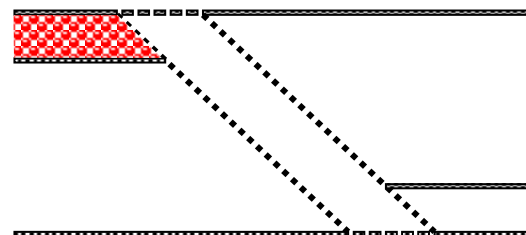

e) Voltage is too high or ions too fast.
No ions in outlet slit.

PASSAGE OF IONS THROUGH THE CHARGED GRIDS

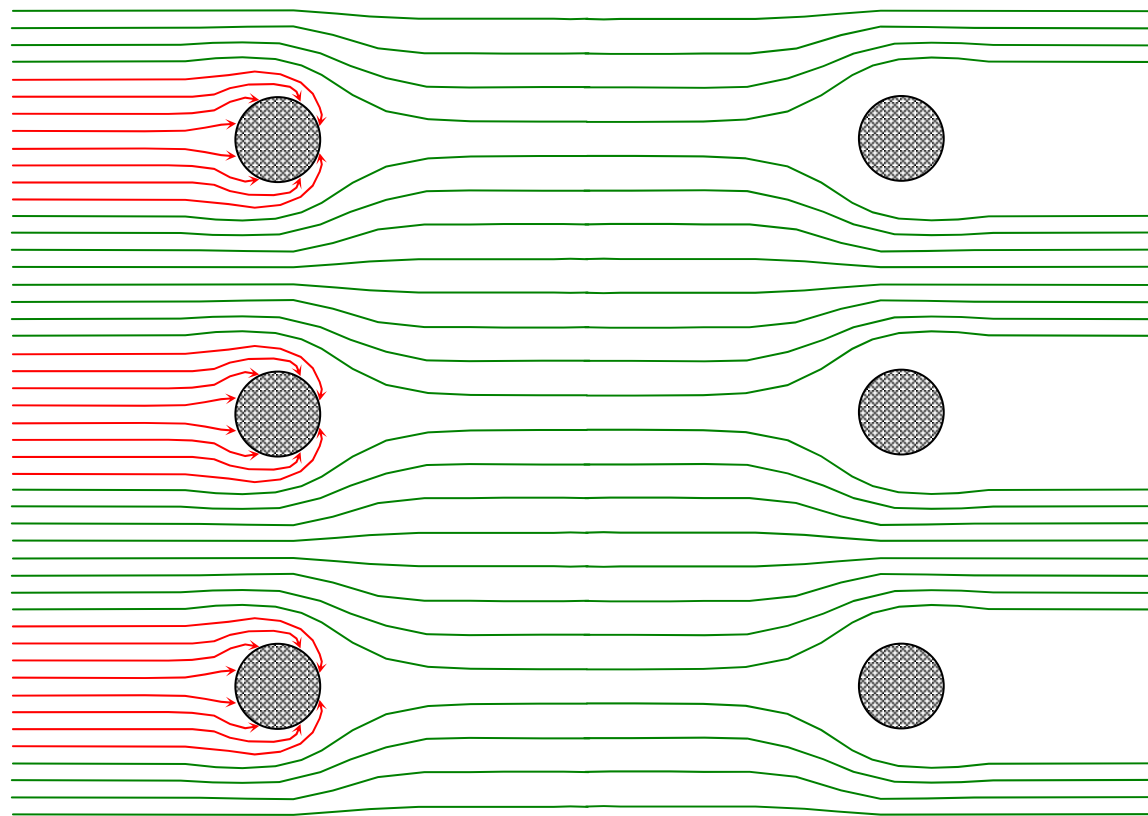

Particles are passing through two grids. First grid is attracting and second one is repelling the particles. Thus some particles are electrically lost on the first grid. Diffusion losses are suppressed on the both grids, as the passing particles are electrically kept away of wire surface. The amount of lost particles is easily calculated using the method of fluxes and the result is presented in next page.

DIFFUSION-FREE TRANSFER FUNCTION OF A PLAIN IGMA

The trajectory calculations and the flux calculations [see *Tammet*, 1970] both are simple. Three critical mobilities are

$$Z_1 = \frac{ud}{V} \frac{1}{1 + (b/a)(b+d-bh/a)/(a-h)},$$

$$Z_0 = \frac{ud}{V} \frac{1}{1 + (b/a)(b+d)/a},$$

$$Z_2 = \frac{ud}{V} \frac{1}{1 + (b/a)(b+d+bh/a)/(a+h)},$$

and the diagram of the transfer function looks as below:



Height of the diagram is:

$$p_0 = \frac{bd}{a^2 + b^2 + bd}.$$

$p_0 < 1$ due to the loss of ions on the first grid (see previous page).

EFFECT OF BROWNIAN DIFFUSION IN A PLAIN IGMA

The Brownian fluctuations of the trajectory are estimated according to the methods explained in the book [Tammet, 1970]. Simple in principle but a technically troublesome calculation yields the result

$$\delta_d = f \times \delta_o,$$

where

$$f = \frac{\sqrt{1 + \frac{d(b+d)}{a^2 + b^2 + bd}}}{\sqrt{1 + \frac{a^2 + b^2}{bd}}}.$$

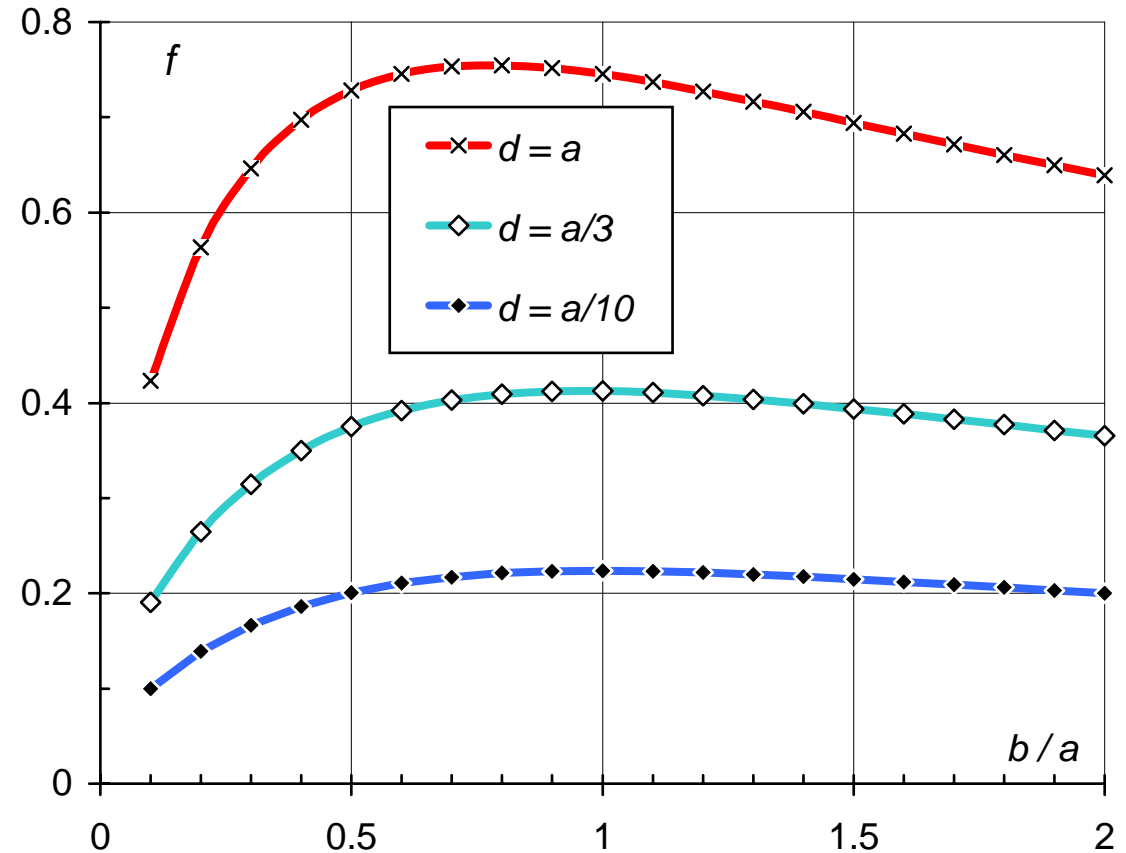

ADVANTAGES AND DISADVANTAGES OF A PLAIN IGMA

Advantages:

- high mobility resolution,
- easy to keep plug air flow in the instrument,
- simple theoretical calculations,
- calculated transfer function could be trusted without comparative calibration.

Disadvantages:

- one of the aerosol inlet or outlet is on high electric potential,
- loss on charged particles on attracting grid,
- driving voltage is not effectively used because the beam of monomobile particles does not fill the space between grids.

The advantages are most essential in analytic applications e.g. electrospray ionization mobility spectrometry, making this method probably competitive when compared with dominating method of drift tube.

The disadvantages are most essential in atmospheric applications where extreme mobility resolution is not required and the technical problems originate from the very low concentration of particles to be measured, typically less than 10 charged particles per ccm in the size range of 2-4 nm.

HOW TO IMPROVE AN IGMA?

1. Cut away the grid between the inlet channel and drift region. Result: no losses of ions on the grids.
2. Cut away the grid between the drift region and outlet channel, switch the outlet channel to the ground potential and arrange a voltage divider (or insulator) between the high voltage grid and the channel. Result: both the outlet and inlet can be kept on the ground potential.

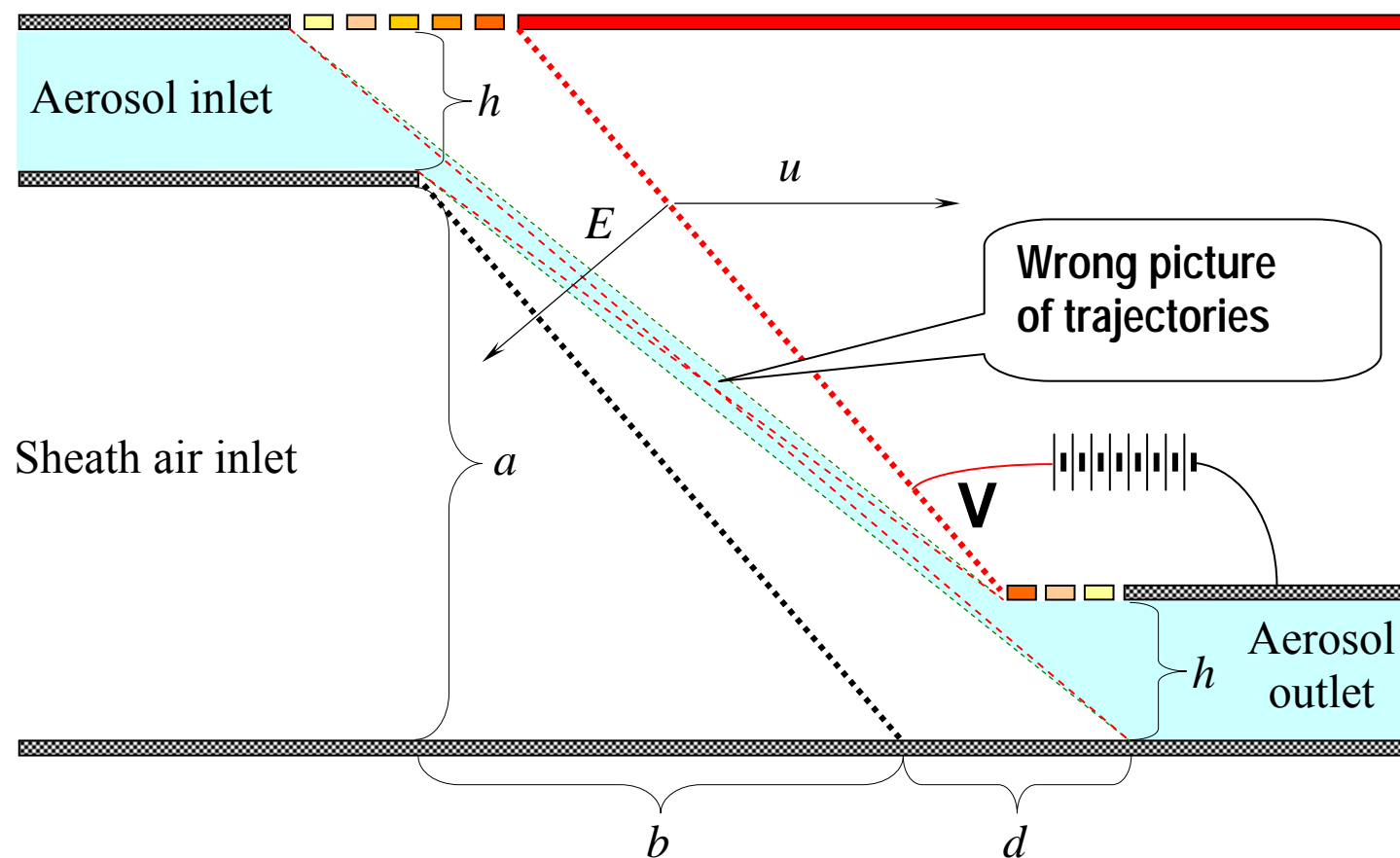

An unwanted result: the trajectories in the picture above are wrong and the calculation of real trajectories requires numerical solution of the Laplace equation.

TRAJECTORIES OF IONS IN A MODIFIED IGMA

(plug air flow is expected)

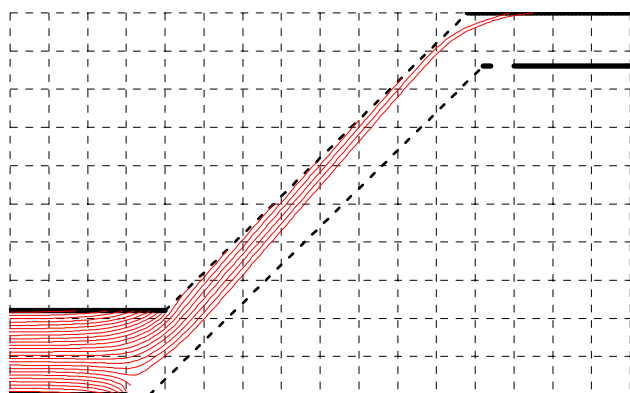

Laminar flow, high mobility

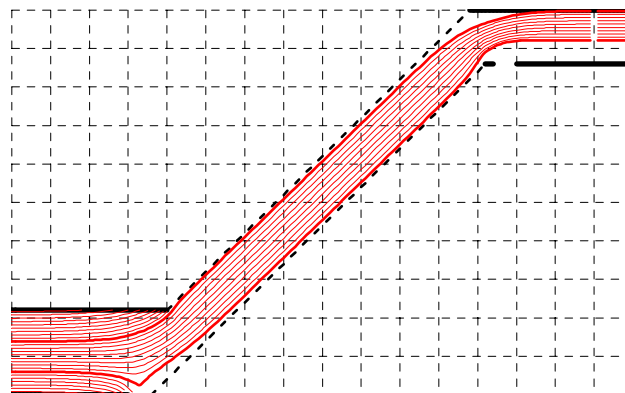

Laminar flow, central mobility

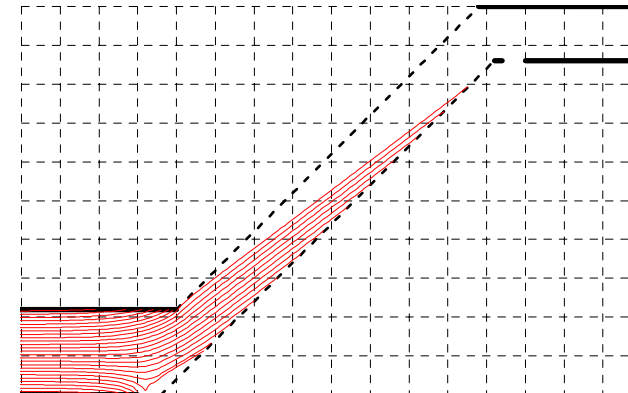

Laminar flow, low mobility

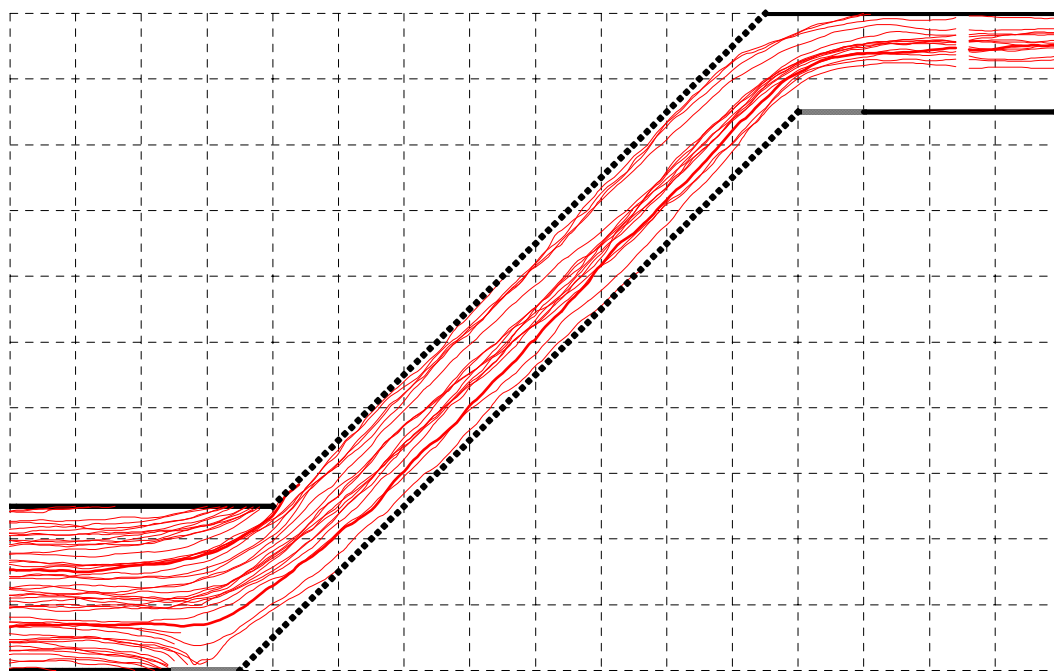

Turbulent flow ($\epsilon = 10\%$), central mobility.

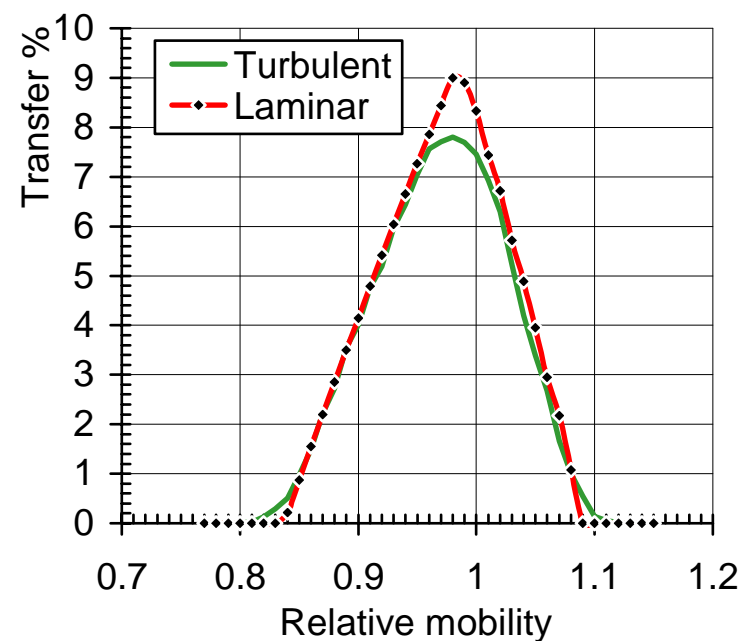

Transfer functions.

THE FIRST IGMA

An improved IGMA for the measurement of the atmospheric intermediate and small air ions has been designed at the Air Electricity Laboratory of the University of Tartu and manufactured by a spin-off company AIREL Ltd. The instrument is intended for the study of nucleation events in the atmosphere and should have both the good sensitivity and high time resolution.



IGMA without the external filter.
Size $53 \times 31 \times 32$ cm, mass 17.5 kg.



IGMA (a side panel off) with the external recirculation filter.
Size $85 \times 31 \times 48$ cm, mass 29 kg.

PERFORMANCE OF THE FIRST IGMA

The mobility range of $0.05\text{--}3.2\text{ cm}^2\text{ V}^{-1}\text{ s}^{-1}$ is logarithmically distributed into 18 fractions. Huge air flow is required to assure the necessary sensitivity. The flow rate in the inlet slit is $0.05\text{ m}^3/\text{s}$. The plug flow is not kept at the full height profile and the velocity of air passing the grids is less than in the ion inlet. The sheath air should be free of ions. A stack of plate electrodes is used as an internal electrostatic filter just before the grid. The effectiveness of this filter is sufficient to cut away the ions of the measured mobility but not sufficient to filter out the space charge carried by large air ions. The fluctuations of the space charge cause random errors or noise in measurements. Thus the ballast air is recirculated to the sheath air and passed on its way through a long electrostatic filter.

The ions in the outlet are collected by a well-insulated and shielded electrostatic filter powered

by an internal battery and DC-DC converter. The collector is connected to the ground through an electrometric amplifier. Electrostatic shielding from the high voltage deflector grid allows free manipulation with mobility control voltage. The deflector grid is connected to a RC circuit with a time constant of about 4 s. The capacitor of this circuit is quickly charged up to 6 kV and slowly discharged through the resistor with a period of 20 s. This assures the logarithmical scanning of mobility from the lowest to the highest value of the mobility range during the 20 s period.

The air ion inlet is equipped with a controlled electrostatic filter that is used as a gate to close or open the ion entrance into the instrument. During the 3 minute recording period the mobility distribution is 9 times scanned through the full range, five times with open inlet gate and four times with closed inlet gate.

SENSITIVITY OF THE FIRST IGMA

The sensitivity is limited by the noise in the electrometer signal. Two factors of noise appeared the most essential: the fluctuations of the space charge of the residue large ions that are not filtered out by the sheath air filter, and the noise generated by the ionization pulses generated by the alpha particles emitted by the deposited in the instrument radon daughters. The ions generated by the alpha particles between the grids are separated by the electric field according to the polarity. If the voltage is high, then the generated small ions are collected on the grids and do not reach the collector. If the characteristic mobility is just in the range of small ions, then the clouds of separated unipolar ions reach the collector and generate noise.

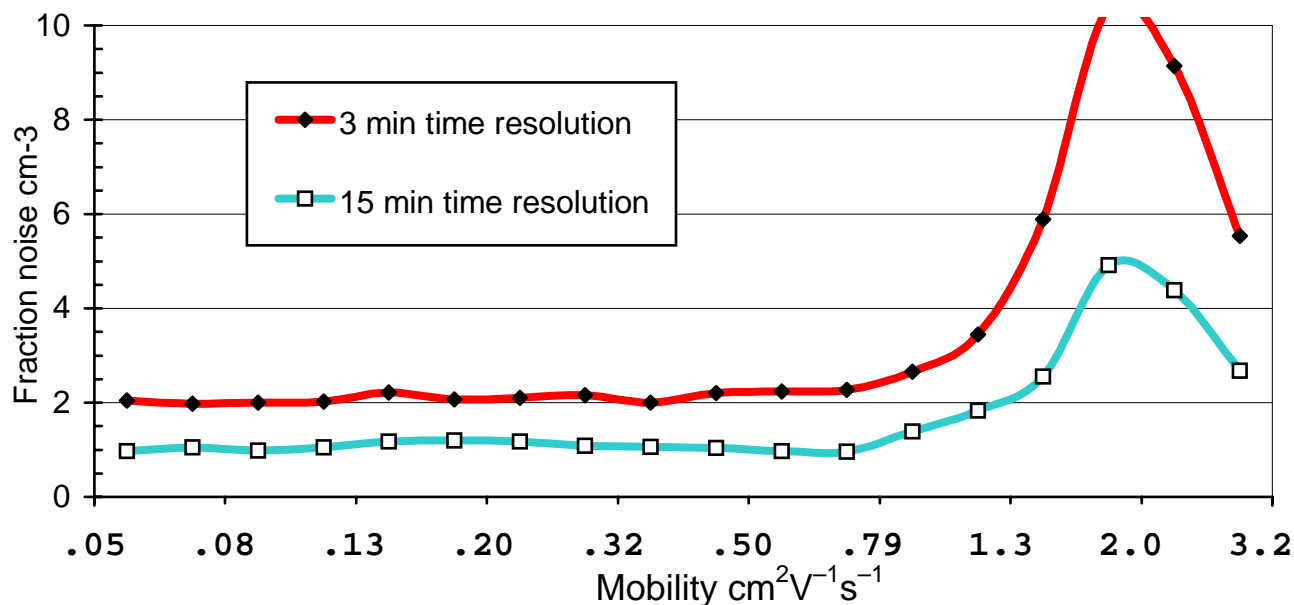

Dependence of the fraction concentration measurement noise on the characteristic mobility in IGMA

EXAMPLE OF MEASUREMENT WITH THE FIRST IGMA

A nucleation event during ANARChE 2002, Atlanta

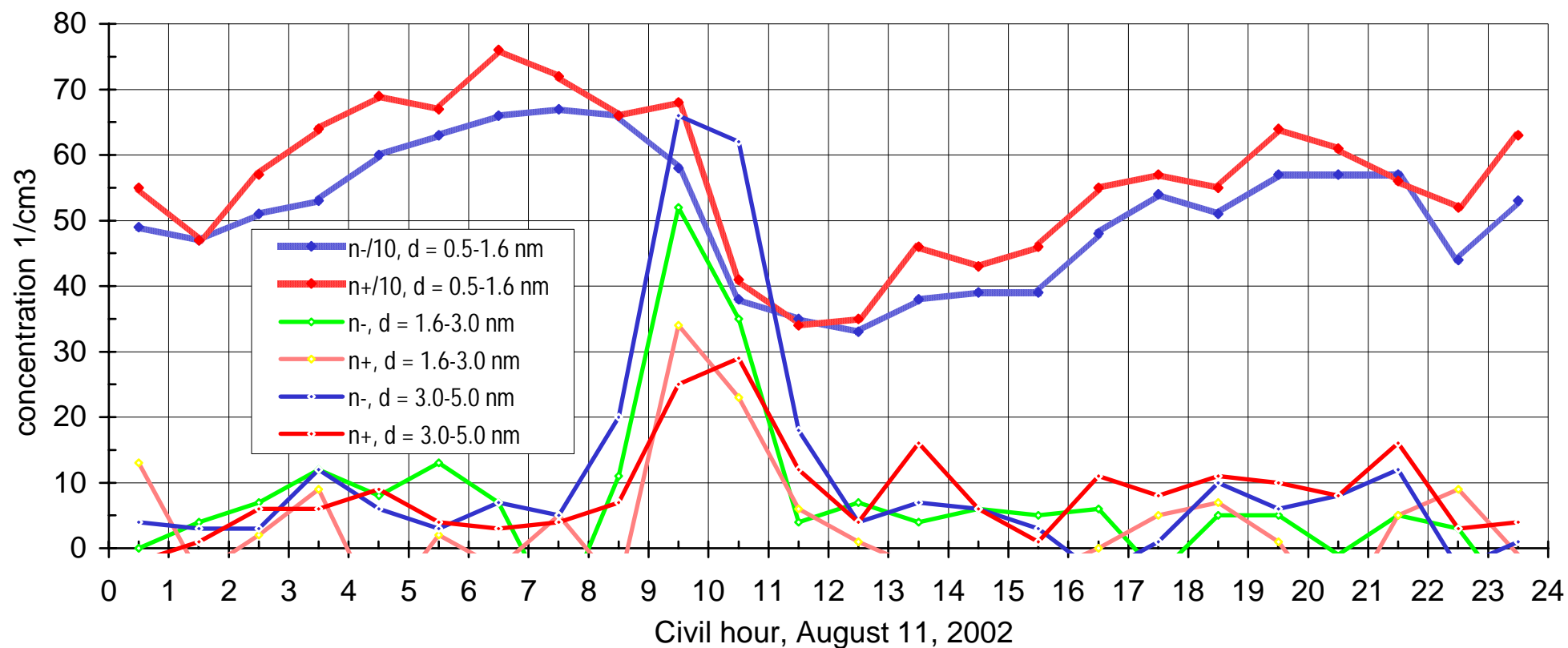

ACKNOWLEDGEMENTS

The author wishes to thank the Estonian Science Foundation (grant 4622) and Prof. P. H. McMurry, University of Minnesota, for supporting this work.

REFERENCES

- Eiceman, G.A., Karpas, Z., *Ion Mobility Spectrometry*, CRC Press, Boca Raton, FL, 1994.
- Flagan R.C., History of electrical aerosol measurements, *Aerosol Sci. Technol.*, **28**, 301–380, 1998.
- Loscertales, I.G., Drift differential mobility analyzer, *J. Aerosol Sci.*, **29**, 1117–1139, 1998.
- Rosell-Llompart, J., I.G. Loscertales, D. Bingham, and J. Fernandez de la Mora, Sizing nanoparticles and ions with a short differential mobility analyzer, *J. Aerosol Sci.*, **27**, 695–719, 1996.
- Tammet, H., *The aspiration method for the determination of atmospheric-ion spectra*, IPST, Jerusalem, 1970. <http://ael.physic.ut.ee/tammet/am/>
- Tammet, H., The limits of air ion mobility resolution. *Proc. 11th Int. Conf. Atmos. Electr.*, NASA, MSFC, Alabama, 626–629, 1999.
- Zeleny, J., On the ratio of velocities of the two ions produced in gases by Röntgen radiation, and on some related phenomena, *Philos. Mag.*, **46**, 120–154, 1898.
- Zeleny, J., The distribution of mobilities of ions in moist air, *Phys. Rev.*, **34**, 310–334, 1929.